



# Transform

A TECHNOLOGICAL REVOLUTION INTO  
DYNAMIC ARCHITECTURE





# TRANSFORM

ARTISTIC SENSIBILITY  
INTO BUSINESS SENSE

**IN THE PAST, THERE WERE PERFORMANCE HALLS FOR THE ARTS AND CONVENTION CENTRES FOR BUSINESS MEETINGS.**

Today, one space can host a conference, a ballet, a cabaret, a product launch, a symphony orchestra, a lecture, a rock concert, or a VIP reception.

**This is the magic of Gala Systems: blending the arts and business within one multipurpose space.**

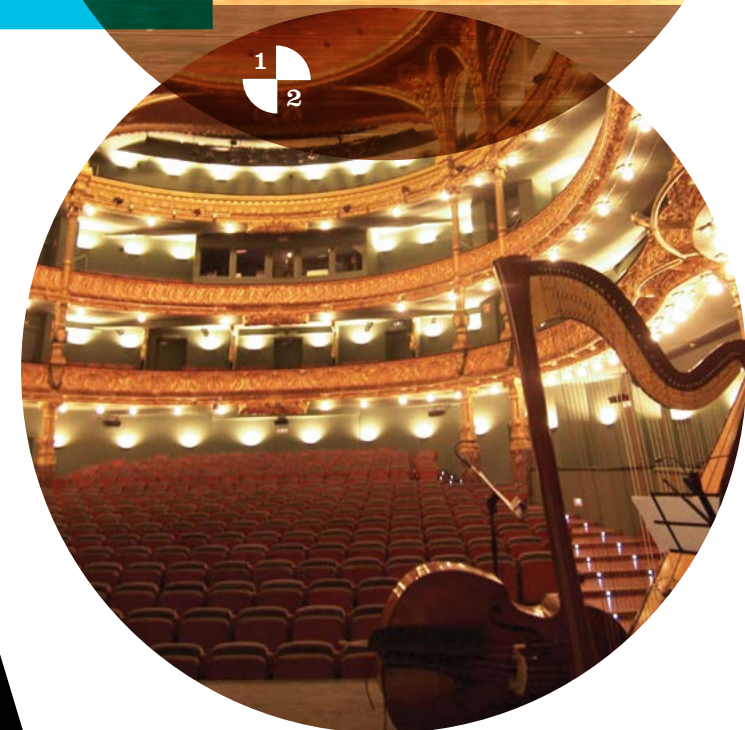

Teatro Campos Eliseos  
Bilbao, Spain

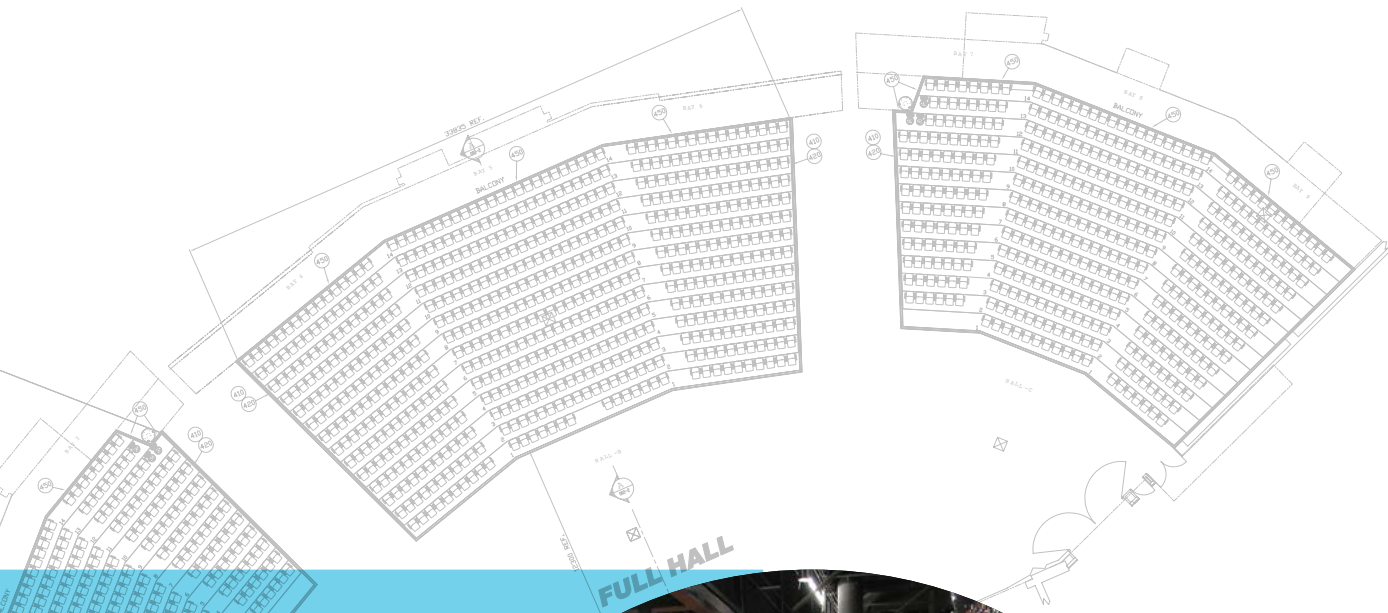

Imagine a room that can completely change its function in less than 10 minutes. Imagine a space where the size, capacity and configuration can adapt to any type of event, whether cultural or commercial, and to any type of audience.

Imagine a room where the stage and seats fold, deploy and tuck themselves away automatically, at the touch of a button. Gala Systems allows the possibility to design a flexible multipurpose space instead of the regular static public venue.

# TRANSFORM

A THEATRE INTO A SEMINAR SPACE  
 AN AUDITORIUM INTO A CABARET  
 A CONFERENCE ROOM INTO A BALLROOM

- 01 **Design of multipurpose rooms** in cultural, commercial, institutional or mixed settings;
- 02 **State-of-the-art Spiralift™ columns;**
- 03 **Integrated systems** for seats, stages and modular floors;
- 04 **Infinite configuration possibilities:** cabaret, flat floor, tiered floor auditorium, etc.;
- 05 **Automated, simple, quick and quiet transformations;**
- 06 **Optimal acoustics** for symphonies and concerts;
- 07 **Impeccable design** in any configuration.

## SPECIAL EVENTS

- Award Ceremonies
- Proms and Galas
- Weddings
- Fundraisers
- Exhibitions
- Cabaret shows
- Sports events
- Conferences
- Etc.

## CORPORATE EVENTS

- Conventions and corporate activities
- Corporate assembly
- Product launches
- Teaching seminars
- Corporate banquets for convention attendees
- Etc.



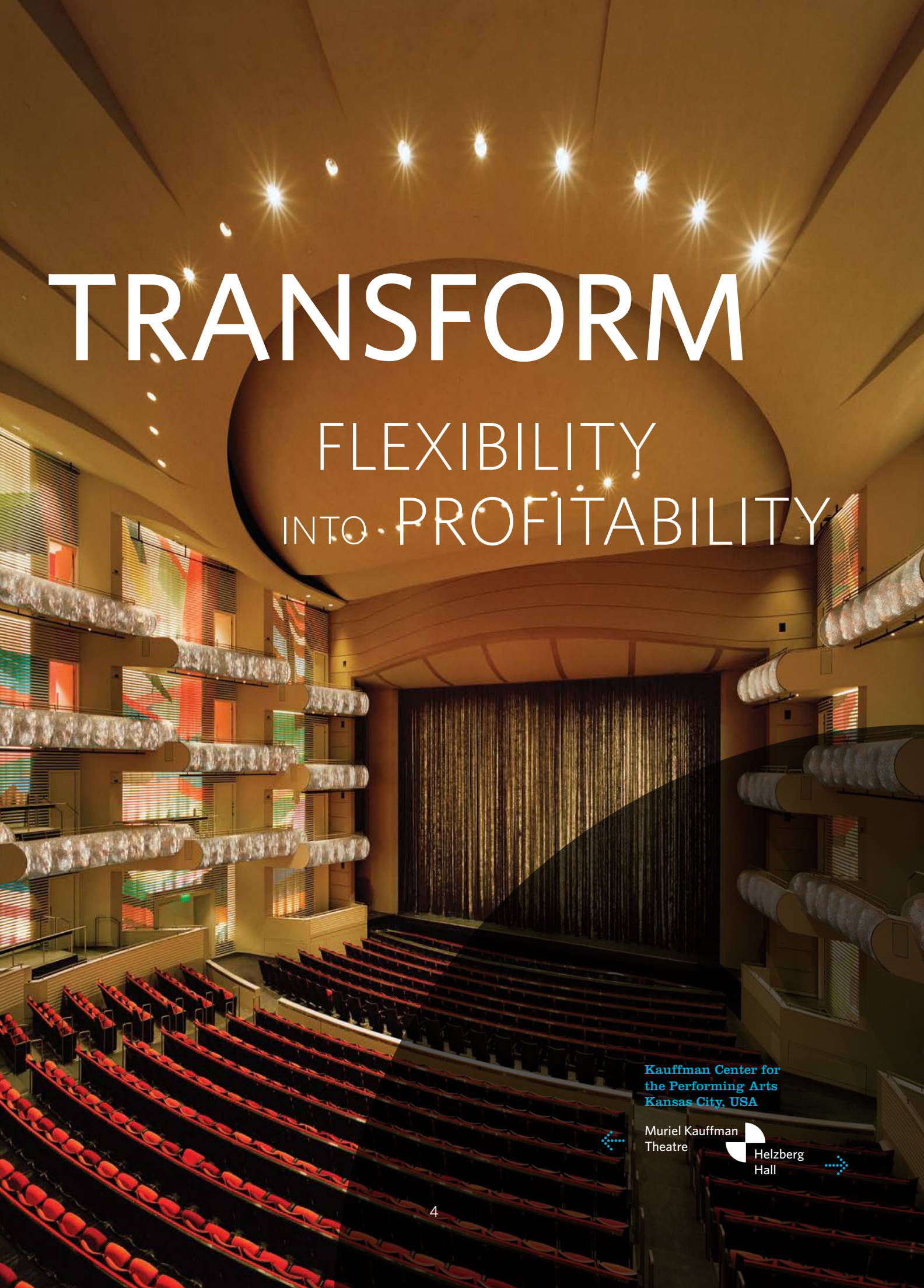

# TRANSFORM

## FLEXIBILITY INTO PROFITABILITY

Kauffman Center for  
the Performing Arts  
Kansas City, USA

Muriel Kauffman  
Theatre

Helzberg  
Hall

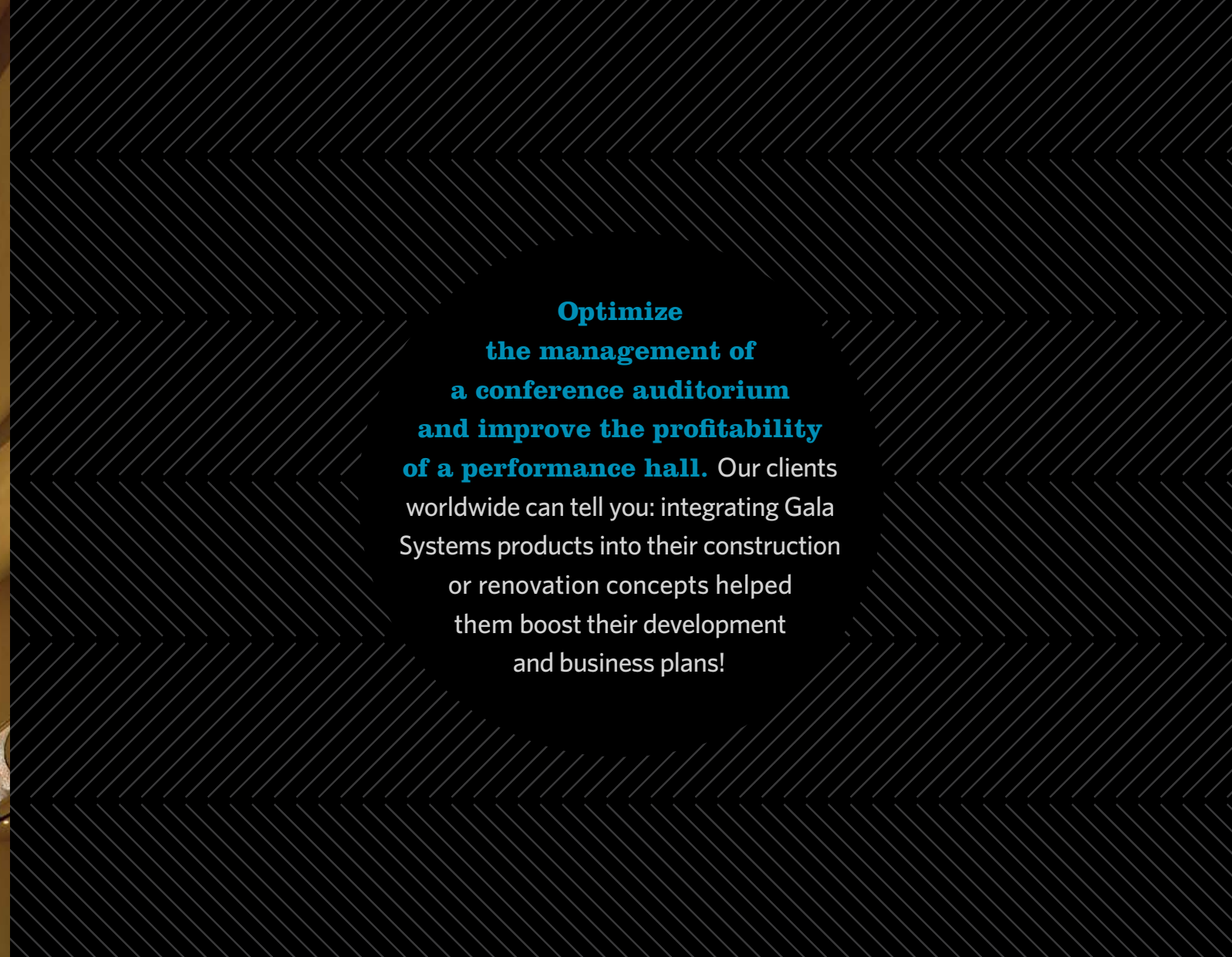

**Optimize**  
**the management of**  
**a conference auditorium**  
**and improve the profitability**  
**of a performance hall.** Our clients  
worldwide can tell you: integrating Gala  
Systems products into their construction  
or renovation concepts helped  
them boost their development  
and business plans!



## 6 FINANCIAL REASONS TO CONSIDER GALA SYSTEMS FOR YOUR PROJECT

**1 Maximize space:**  
A modular space allows for  
increased total capacity when  
needed. For example, a 400-seat  
room can accommodate up to  
600 people for a cocktail reception.

**2 Increase rental revenues:**  
Accommodate multiple events in a  
single day within the same room,  
thanks to quick turnaround times.

**3 Increase your potential client base:**  
Comprehensive and multipurpose,  
Gala spaces adapt to any type  
of project, from theatre and music  
to commercial or institutional.

**4 Increase associated income**  
thanks to the ability to host  
banquets and cabaret evenings,  
which generate food and  
beverage sales.

**5 Reduce operating costs:** Gala Systems offers  
an entirely automated solution, so  
just one technician can reconfigure  
a room for a new event.

**6 No wear and tear:**  
The Gala Venue system is designed  
to operate for the full life of the  
venue. Fully automated, the system  
has no wear and tear on seats and  
finishes.

# TRANSFORM

EVERY CHALLENGE  
INTO LIMITLESS POSSIBILITIES

**HAVING A VISION FOR  
A MULTIPURPOSE  
HALL IS GOOD, BUT  
BEING ABLE TO  
MAKE IT A REALITY  
BY OPTIMIZING  
ARCHITECTURAL AND  
STRUCTURAL DESIGN  
IS EVEN BETTER.**

Because they are custom-designed for each project, Gala Systems products can be easily integrated into any environment: they can be designed as part of a new build, or incorporated into existing or even historic spaces. No matter the challenge, the solution is simple - for you, for the venue manager, and for the operator.



Melbourne Convention and Exhibition Centre  
Melbourne, Australia



- 01** Integrated, incognito and entirely **automated systems**
- 02** **Simple operation** with a remote control panel
- 03** **Ability to preset** and recall any configuration
- 04** **Rapid transformation** within 10 to 30 minutes
- 05** **Minimal handling required:** a single employee can deploy several configurations at the touch of a button
- 06** **Quiet movement** that won't hinder or disturb activities in adjacent rooms
- 07** **Customized design:** a wide range of options and materials to choose from for seats and floors, with the same acoustic qualities and durability as in fixed auditoriums

# OVER 1500 PROJECTS IN 65 COUNTRIES

For over 30 years, Gala Systems has been providing its know-how and technological expertise to prestigious cultural institutions and conference centres around the world, and has become a leader recommended by renowned venues. Today, our name is associated with over 1,500 installations, including over 30 made-to-measure custom multifunctional spaces.



## Americas

- 2014 Club Regent Casino, **Winnipeg, Canada**
- 2014 Tobin Center for the Performing Arts, **San Antonio, USA**
- 2009 The Air Canada Centre, **Toronto, Canada**
- 2006 Hard Rock Showroom, **Coquitlam, Canada**
- 2006 Schermerhorn Symphony Center, **Nashville, USA**
- 2005 River Rock Show Theatre, **Richmond, Canada**
- 2003 Verizon Hall and Perelman Theater, Kimmel Center for the Performing Arts, **Philadelphia, USA**
- 2002 Salle Pierrette-Gaudreault, Centre culturel du Mont-Jacob, **Saguenay, Canada**

## Asia and Oceania

- 2010 Pesna Multipurpose Hall, **Moscow, Russia**
- 2007 Melbourne Convention & Exhibition Centre (MCEC), **Melbourne, Australia**
- 2007 Barvikha Luxury Village Concert Hall, **Barvikha, Russia**
- 2006 National Convention Centre, **Hanoi, Vietnam**
- 1997 Kanagawa Arts Theatre (KAAT), **Yokohama, Japan**

## Europe

- 2015 Klaipeda Drama Theatre, **Klaipeda, Lithuania**
- 2015 Philharmonie de Paris, **Paris, France**
- 2014 Intesa Sanpaolo Head Office, **Turin, Italy**
- 2014 SwissTech Convention Center (EPFL), **Lausanne, Switzerland**
- 2013 Lennox Suite, Edinburgh International Conference Centre (EICC), **Edinburgh, Scotland**
- 2012 Centro de Innovación Tecnológica del Entretenimiento, **Seville, Spain**
- 2012 Fórum Evolución Palacio de Congresos, **Burgos, Spain**
- 2012 Stavanger Konserthus, **Stavanger, Norway**
- 2010 Teatro Campos Elíseos, **Bilbao, Spain**
- 2007 Theater Heerlen, **Heerlen, Netherlands**
- 2007 Rotterdamse Schouwburg, **Rotterdam, Netherlands**
- 2004 KVS - The Brussels City Theatre, **Brussels, Belgium**
- 2003 Philharmonie Essen, **Essen, Germany**
- 2002 Stock Exchange Theatre, **Ghent, Belgium**
- 1999 Royal Opera House, Covent Garden, **London, United Kingdom**
- 1999 Teatro Lliure, **Barcelona, Spain**
- 1996 Freiburg Convention Centre, **Freiburg, Germany**
- 1995 Maison de la culture du Japon, **Paris, France**

→ **Perelman Theater, Kimmel Center for the Performing Arts, Philadelphia, USA**

→ Centro de Innovación Tecnológica del Entretenimiento, Seville, Spain

# Transform

ONE LOCATION INTO A  
MULTI-USE DESTINATION  
IN THE HEART OF THE CITY

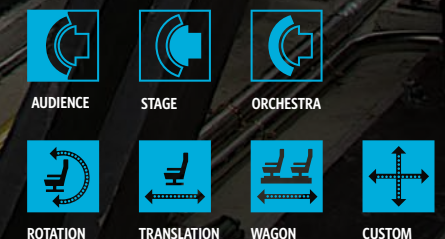

# Transform

ONE LOCATION INTO A  
MULTI-USE DESTINATION  
IN THE HEART OF THE CITY





## **MAISON SYMPHONIQUE**

**Montreal, Quebec, Canada**

- Large orchestra lift, 3 automated seating wagons with rows of mounted seats  
Number of transformable seats: 80
- One large chorus riser wagon with lift  
Number of transformable seats: 40

**CLIENT:**  
**SNC-LAVALIN**

**ARCHITECT:**  
**JACK DIAMOND**





## **CLUB REGENT CASINO**

**Winnipeg, Manitoba, Canada**

- Multipurpose hall with rotation transformation seats
- Number of transformable seats: 960
- Total number of seats: 1,392

**CLIENT:**  
**MANITOBA LOTTERIES**

**ARCHITECT:**  
**NUMBER TEN  
ARCHITECTURAL GROUP**





# FÓRUM EVOLUCIÓN PALACIO DE CONGRESOS

**Burgos, Spain**

- Transformation with translation of three orchestra lifts with each row of seats moving independently to a storage position under the adjacent row
- Number of transformable seats: 160
- Total number of seats: 800

**CLIENT:**  
CITY OF BURGOS

**ARCHITECT:**  
JUAN NAVARRO BALDEWEG





# SALLE PIERRETTE-GAUDREULT CENTRE CULTUREL DU MONT-JACOB

Saguenay, Quebec, Canada

- Multipurpose hall with rotation transformation seats
- Number of transformable seats: 330
- Total number of seats: 396

CLIENT:  
CITY OF SAGUENAY

ARCHITECT:  
BERTRAND DALLAIRE





## **RIVER ROCK SHOW THEATRE** **Richmond** **HARD ROCK SHOWROOM** **Coquitlam** **British Columbia, Canada**

### **River Rock Show Theatre**

- Multipurpose hall with rotation transformation seats
- Number of transformable seats: 706
- Total number of seats: 950

### **Hard Rock Showroom**

- Multipurpose hall with rotation transformation seats
- Number of transformable seats: 784
- Total number of seats: 1,100

**CLIENT:**  
**GREAT CANADIAN GAMING  
CORPORATION**

**ARCHITECT:**  
**CHRIS DIKEAKOS ARCHITECTS**





# TEATRO CAMPOS ELÍSEOS

Bilbao, Spain

- Multipurpose hall with rotation transformation seats
- Number of transformable seats: 303
- Total number of seats: 795

**CLIENT:**

SOCIEDAD GENERAL DE AUTORES Y EDITORES (SGAE) - CITY OF BILBAO

**ARCHITECT:**

ESTUDIO SANTIAGO FAJARDO





# CENTRO DE INNOVACIÓN TECNOLÓGICA DEL ENTRETENIMIENTO (CITE)

Seville, Spain

- Multipurpose hall with rotation transformation seats
- Number of transformable seats: 1,000
- Total number of seats: 1,600

**CLIENT:**  
SOCIEDAD GENERAL DE AUTORES Y EDITORES (SGAE)

**ARCHITECT:**  
ESTUDIO SANTIAGO FAJARDO





## SWISSTECH CONVENTION CENTER – EPFL

### Lausanne, Switzerland

- Multipurpose hall with rotation transformation seats
- Number of transformable seats: 2,300
- Total number of seats: 3,000
- 2 large stage lifts and 1 movable wall

**CLIENT:**  
HRS REAL ESTATE LTD

**ARCHITECT:**  
RICHTER DAHL ROCHA & ASSOCIÉS





# TOBIN CENTER FOR THE PERFORMING ARTS

San Antonio, Texas, USA

- Multipurpose hall with rotation transformation seats
- Number of transformable seats: 722
- Total number of seats: 1,759

CLIENT:  
BEXAR COUNTY PERFORMING ARTS  
CENTER FOUNDATION

ARCHITECT:  
LMN ARCHITECTS





## **KAUFFMAN CENTER FOR THE PERFORMING ARTS**

**Kansas City, Missouri, USA**

### **Helzberg Hall**

- 6 orchestra risers
- Total number of seats: 1,600

### **Muriel Kauffman Theatre**

- 2 orchestra lifts
- 1 sound cockpit lift
- Total number of seats: 1,800

**CLIENT:**  
**THE CITY OF KANSAS CITY**

**ARCHITECT:**  
**SAFDIE ARCHITECTS**





# KIMMEL CENTER FOR THE PERFORMING ARTS

Philadelphia, PA, USA

## Verizon Hall

- Concert hall
- 2 orchestra lifts, 3 choral lifts,  
1 piano lift and 1 sound mix lift
- Total number of seats: 2,500

## Perelman Theater

- Recital theater
- 1 auditorium seating lift and  
7 seat wagons
- Total number of seats: 650

CLIENT:  
REGIONAL PERFORMING ARTS  
CENTER (RPAC)

ARCHITECT:  
RAFAEL VIÑOLY





# BAKU INTERNATIONAL CONFERENCE CENTRE

SCHEDULED TO BE COMPLETED IN SUMMER 2015

## Baku, Azerbaijan

- Multipurpose hall with rotation transformation seats
- Number of transformable seats: 2,000
- Total number of seats: 3,500
- 2 large stage lifts

### CLIENT:

STATE PROPERTY ISSUES  
COMMITTEE OF AZERBAIJAN  
REPUBLIC

### ARCHITECT:

COOP HIMMELB(L)AU





# STAVANGER KONSERTHUS

Stavanger, Norway

**Fartein Valen**

- 1,500-seat orchestra hall

**Zetlitz**

- 1,900-seat multi-purpose hall

**CLIENT:**  
MUNICIPALITY OF STAVANGER

**ARCHITECT:**  
RATIO ARKITEKTER AS





# EDINBURGH INTERNATIONAL CONFERENCE CENTRE (EICC) LENNOX SUITE

**Edinburgh, Scotland, UK**

- Multipurpose hall (1,600 m<sup>2</sup>) with 21 platforms
- 2,000 seats convert into a raked auditorium, a central stage arena and a tiered cabaret configuration
- Can be separated into 3 different halls

**CLIENT:**  
CITY OF EDINBURGH COUNCIL

**ARCHITECT:**  
BDP ARCHITECTS



**GALA SYSTEMS**  
**Creative solutions**



AUDIENCE



STAGE



ORCHESTRA



ROTATION



TRANSLATION



WAGON



CUSTOM

[galasystems.com](http://galasystems.com)

# TRANSFORM

A TECHNOLOGICAL  
BREAKTHROUGH INTO A  
PRACTICAL SOLUTION

GALA SYSTEMS'  
GREATEST STRENGTH  
IS OUR **SPIRALIFT™**  
TECHNOLOGY,



on which rests - both literally and figuratively - our automated transformation systems. But equally important is our ability to integrate this know-how to deliver complete, turn-key solutions.

Our goal? To create, for you and with you, a space that casts every event in the best possible light, and will delight each audience with a memorable experience.

**Versatile orchestra and stage lift solutions for auditoriums and concert halls:**

- Orchestra podiums
- Theater, scenery and piano lifts
- Stage and chorus risers
- Turntable systems
- Seating wagons
- Etc.

**Know-how integrates intelligently into creative,** made-to-measure solutions, working in collaboration with architects, designers and general contractors.

**A complete range of services,** including design, engineering, delivery, installation, training and maintenance.

1 **Mystère - Cirque du Soleil,**  
Las Vegas, USA

2 **Stavanger Konserthus,**  
Stavanger, Norway

3 **Freiburg Convention Centre,**  
Freiburg, Germany

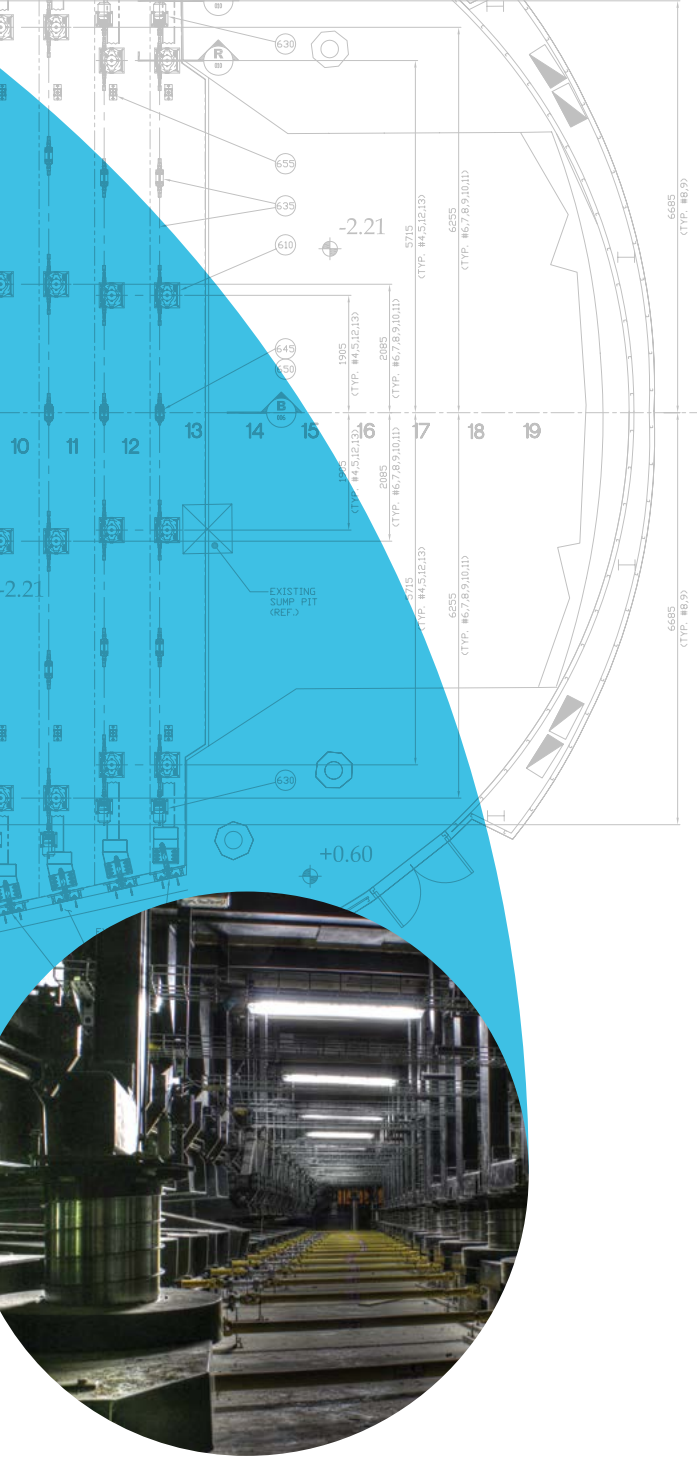

**We are  
A TECHNOLOGICAL REVOLUTION**

Our intelligently engineered and technologically advanced systems are designed to handle large loads with ease, for example, in automotive applications <sup>(1)</sup> and truck lifts. The Spiralift™, our exclusive technology, has also been proven in other rigorous industries, such as aerospace, food, life sciences, and information technology sectors. Efficient, stable and compact, the lifting column's stainless steel material is also non-corrosive, and therefore ideal for use in underwater applications such as movable pool floors <sup>(2)</sup>.



**We are  
A WORLDWIDE PRESENCE**

The following are just a few examples of Spiralift's proven success, with more than 20,000 units installed to date.

- Automotive skillet lifter
- Adjustable height skids
- Automated guided vehicles (AGV Lifts)
- Ergonomic lift tables
- Aircraft engine assembly positioning tables
- Test tables
- Tooling lifts
- Lift tables
- Maintenance platforms
- Flight simulator transfer tables
- Truck lifts
- Jury lifts
- Witness lifts
- Movable swimming pool floors



**We are  
A GLOBAL NETWORK**

Architects, projects planners, theatrical consultants and entrepreneurs: wherever you are in the world, our engineers can customize an automated solution for your specific project. Gala has developed a global network of certified partners who share our vision for flexibility and efficiency.

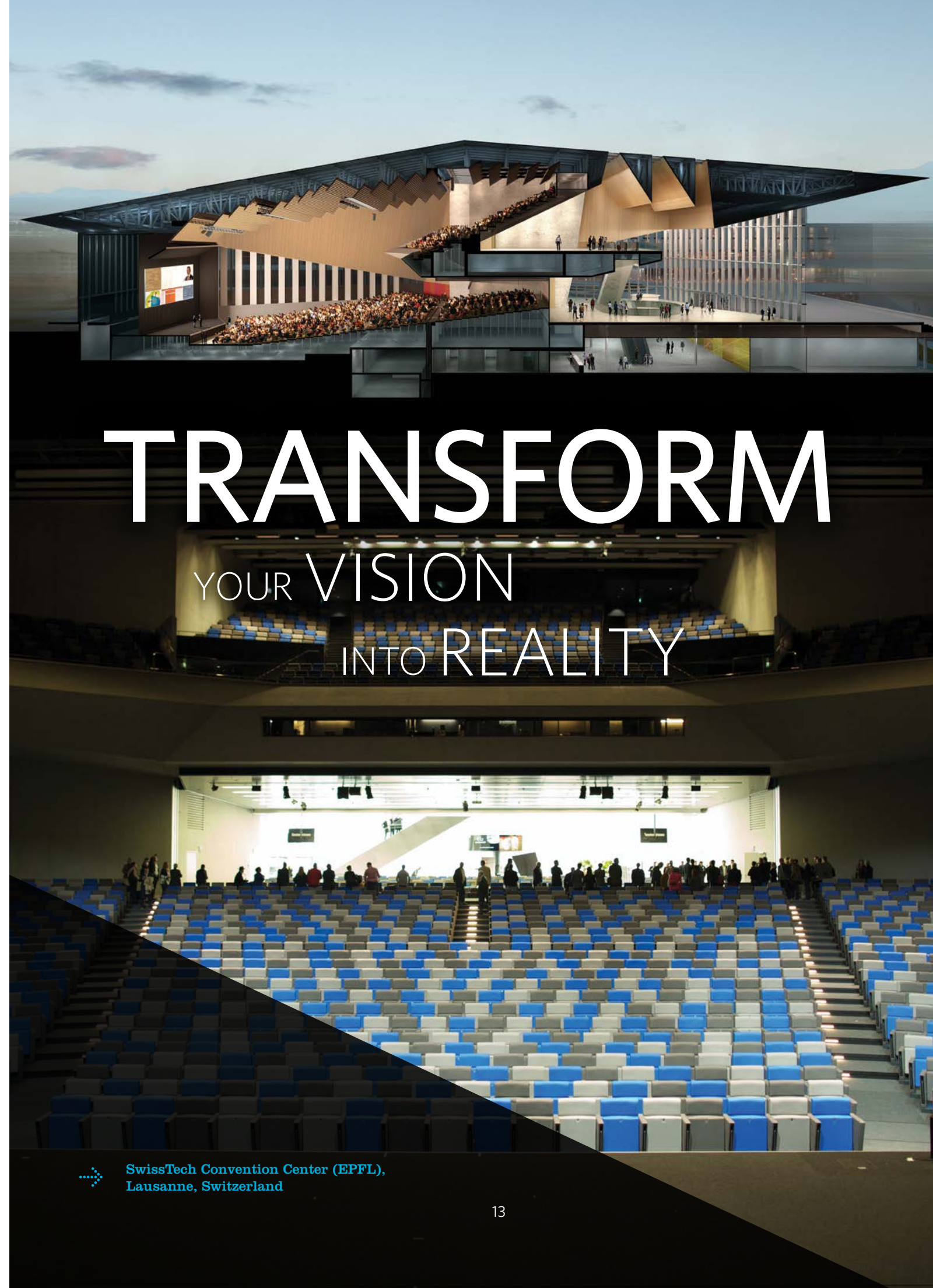

**TRANSFORM**  
YOUR VISION  
INTO REALITY

**GALA SYSTEMS**  
**Creative solutions**

**HEAD OFFICE**

3185 First Street, Saint-Hubert, QC J3Y 8Y6, Canada  
+ 1 450 678-7226 or 1 800 463-7226

*Toll-free in North America*

**info@galasytems.com**

**AMERICAS AND ASIA**

+ 1 760 738-5555 or 1-866-647-5046

*Toll-free in North America*

**galaamerica@galasytems.com**

**ITALY**

+ 39 02-43315505

**galaitaly@galasytems.com**

**ELSEWHERE IN EUROPE**

+ 34 697-180801

**galaspain@galasytems.com**

**galasytems.com**